

# Sunrise Ridge Algae Inc.

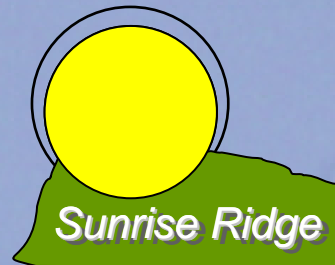

**21 October 2009**

# We Produce “Bioleum” Crude Oil

Carbon dioxide  
+  
Waste water  
+  
Waste heat

Unique  
Algae  
Conversion  
Process

Integrated  
with  
Industrial /  
Cement  
Plants

“Bioleum” crude oil  
+  
Char coal substitute



# Company Qualifications

- Multiple **patents** in algae growth, harvesting and product conversion
- Real-world **pilot operations**, over two years, proving our technology at small scale (kg/day)
- **Experienced team** with specific skills in scale-up, liquid fuels, and negotiations
- **Partnering** with major EPC contractor, cement companies, Universities and City of Austin



# High Heating Value “Bioleum” for Petroleum Refinery Feedstock

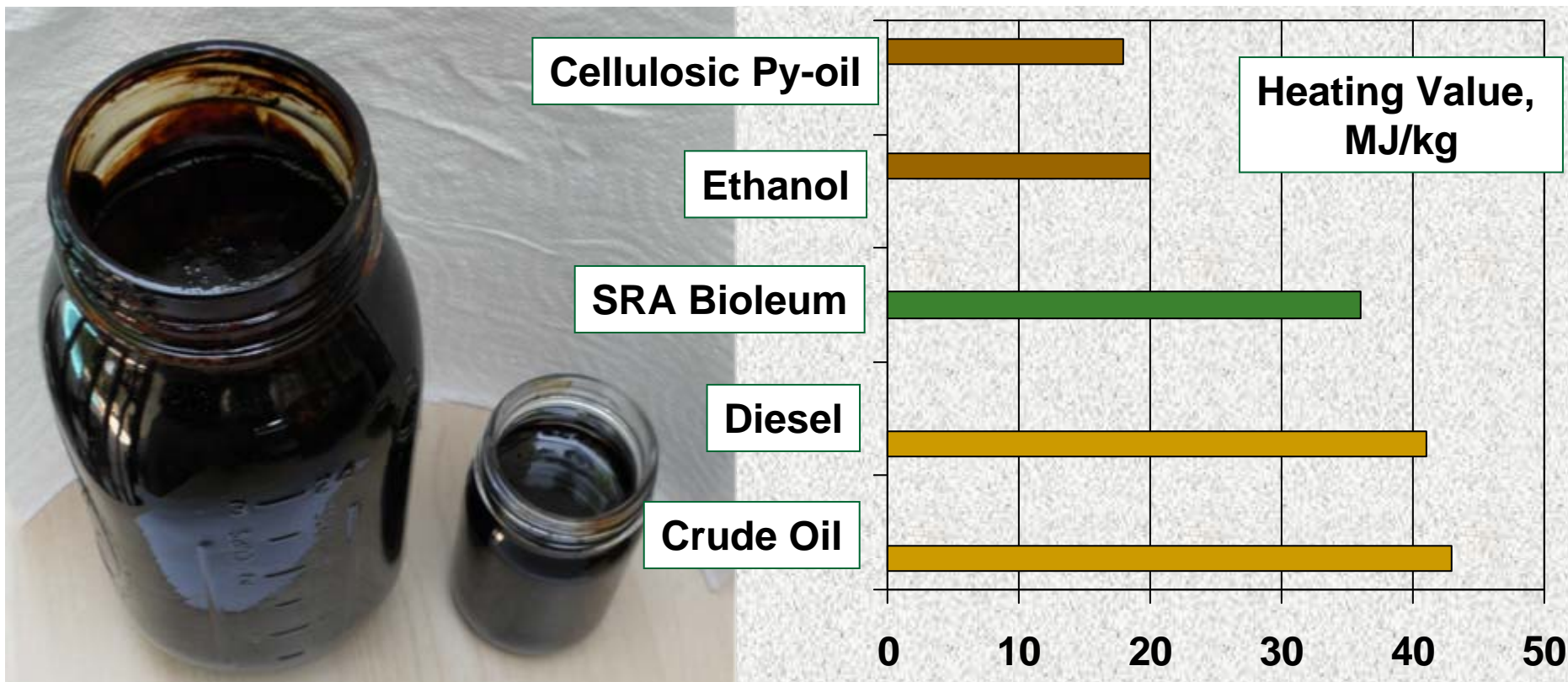

Testing underway with major refiner

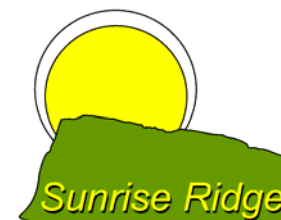

# How are we Different?

## “Standard” Algae-to-Biodiesel

- Selected algae strains, “pushed” to high lipid content
- Expensive photobioreactors
- Complex lysing and extraction process
- Triglyceride oils for biodiesel feedstock
- High protein for animal feed

## SRA Algae-to-Bioleum

- Algae ecology optimized to grow “energy” not lipids
- Inexpensive farming approach
- Drying using waste heat
- Catalytic thermolysis to produce bioleum for refining
- Char for coal replacement

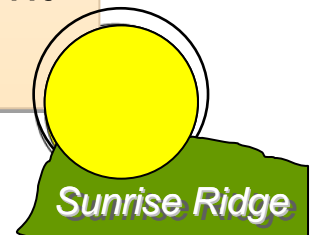

# Example: Cement

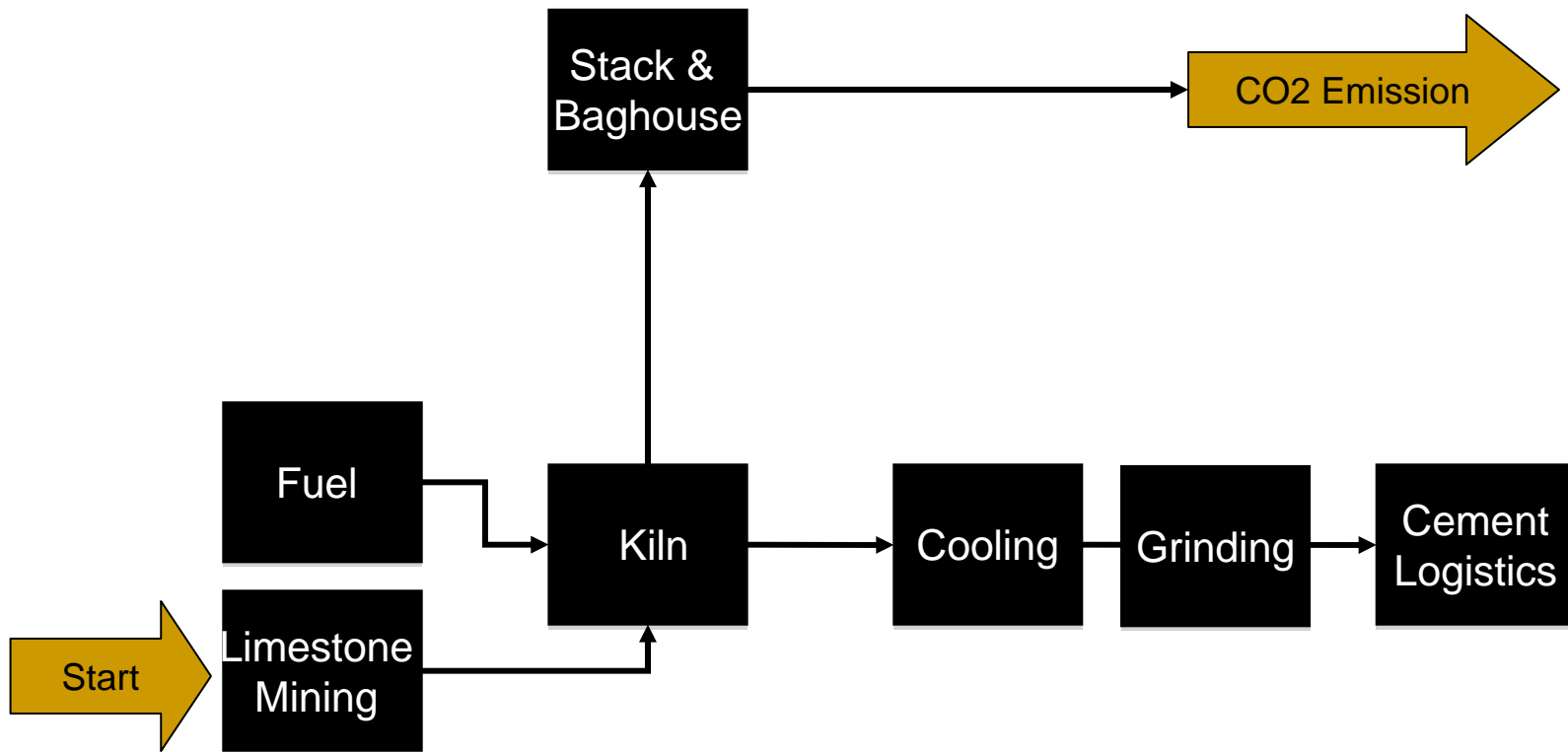

~0.9 Tons CO<sub>2</sub> per ton of Cement Produced



# Integrated Operations

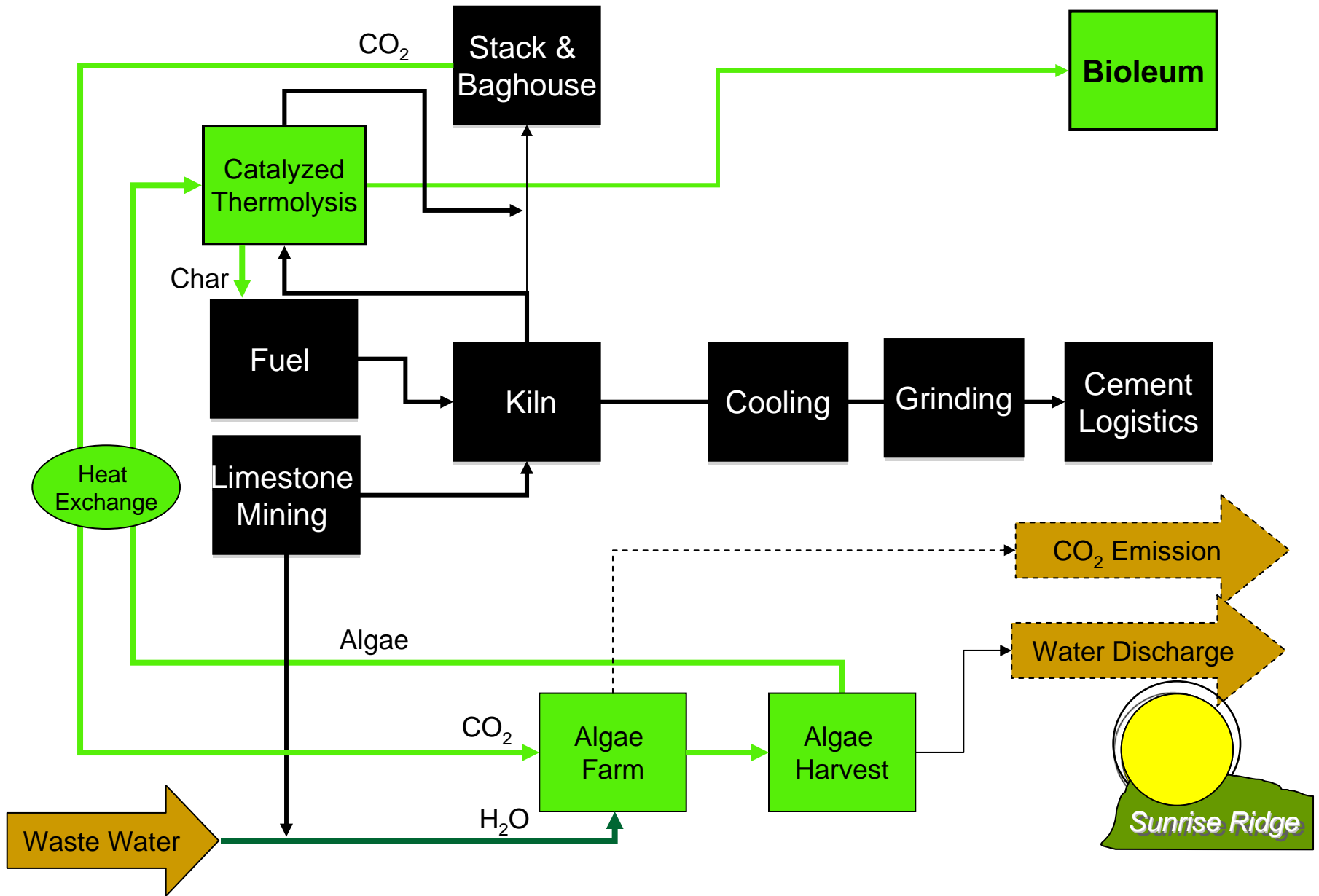

# Our Competitive Advantages

## Thermochemical Conversion process

- Consistency high bioleum yields – 25% from 4% lipid content
- Flexible feedstock
- Co-product char has very large potential market as a coal substitute
- Inexpensive to build and operate

## Site-Oriented Business Model

- Joint venture with industrial site to secure inputs and land
- Long term contracts
- Integrates end-market for oil and char
- “Independent oil producer” model where we sell crude oil to refineries

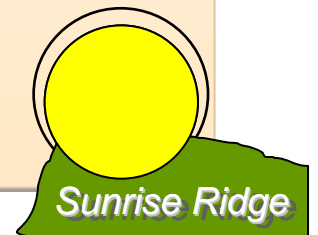

# Funding

- ETF Pre-seed Award 2008
  - \$250K
  - Milestones completed this September
  - Additional \$750K may be available
  
- Currently Seeking DOE Funding
  - Cost-shared Proposals for 80% of Cost of “1 Ton Per Day” scale
  
- Currently Seeking Strategic Investors
  - 2010 Demonstration
  - 2011 Commercial Unit #1



# Timing

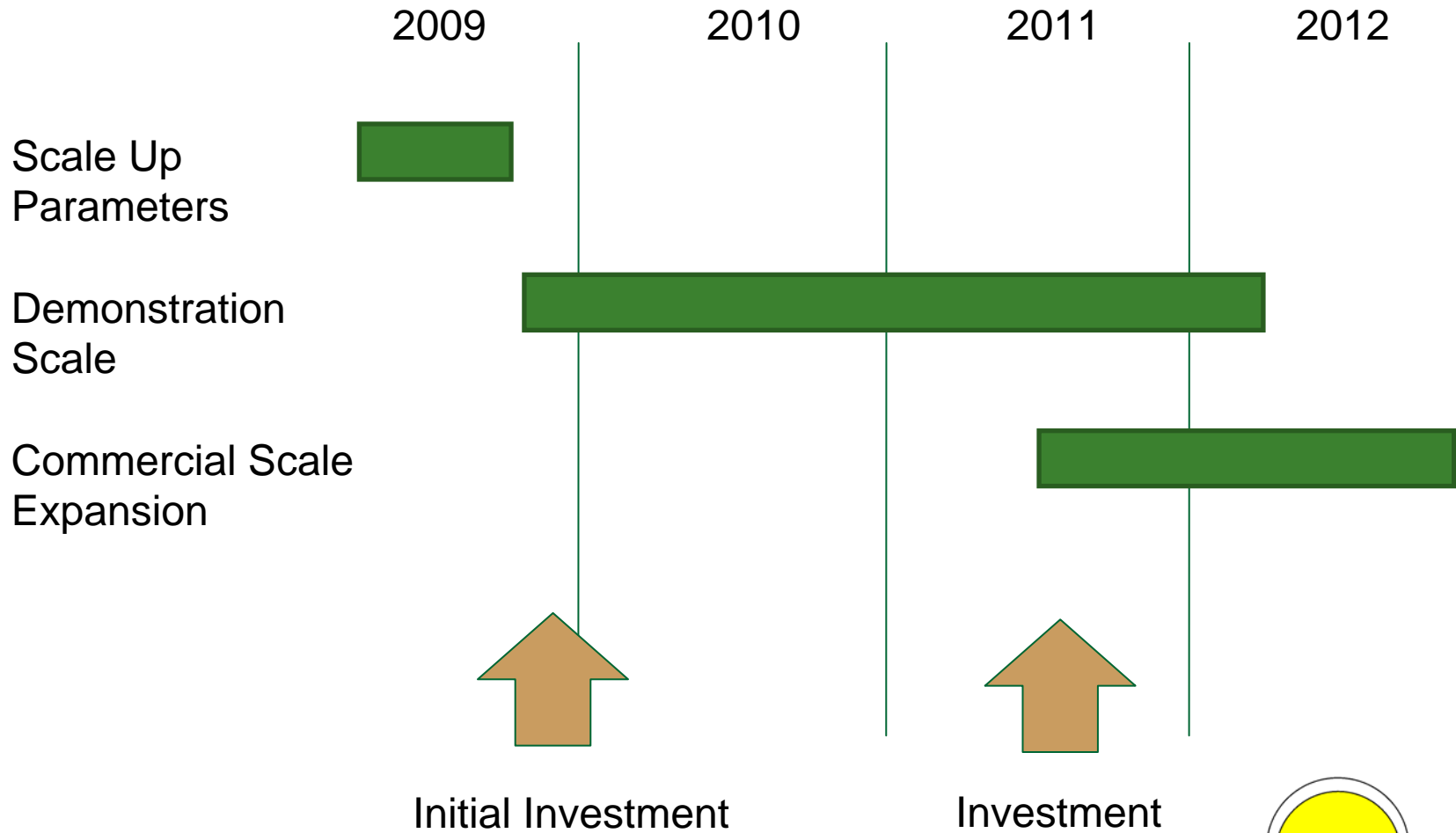

# Sunrise Ridge Algae Inc.

[www.sunrise-ridge.com](http://www.sunrise-ridge.com)

CEO Norman M. Whitton

[norm.whitton@sunrise-ridge.com](mailto:norm.whitton@sunrise-ridge.com)

“See us in  
the  
Showcase!”

